

## Thermal Engineering

**Q.1** Discuss and explain the following (any four)

20

a. **Higher and lower heating value of fuel.**

Ans: The calorific value or heating value of the fuel is defined as the energy liberated by the complete oxidation of a unit mass or volume of fuel.

The higher heating value, HHV is obtained when the water formed by combustion is completely condensed,

The lower heating value, LHV is obtained when the water formed by combustion exists completely in the vapor phase.

$$(\text{HHV})_p = (\text{LHV})_p + m h_{fg}$$

$$(\text{HHV})_v = (\text{LHV})_v + m(u_g - u_f)$$

b. **Methods to improve efficiency of gas turbine.**

Ans: To improve efficiency of gas turbine regeneration method is used. By using regeneration method the heat supplied can be reduced. Due to the reduction in heat supplied the efficiency will be improved.

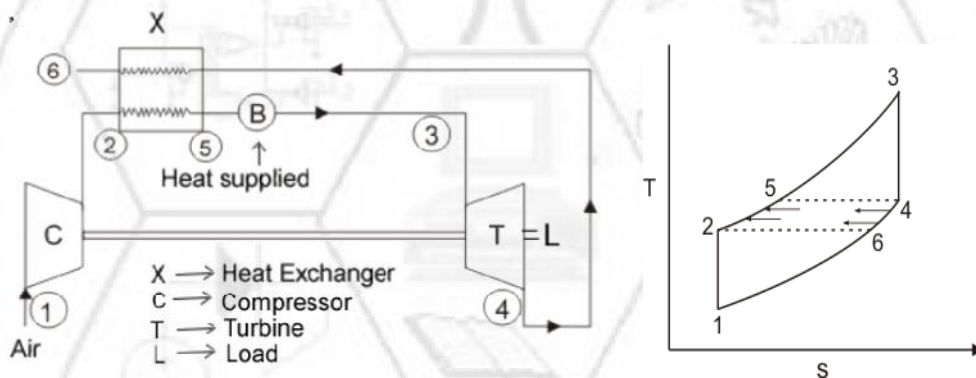

1-2 Isentropic Compression

2-3 Regeneration

3-4 Constant Pressure Heat addition

4-5 Isentropic Expansion

5-6 Heat rejection

c. **Importance of multistaging and intercooling in compressor.**

Ans: When it is required to deliver gases at high pressure, it is advantageous to compress the air or gas in more than one cylinder with intercooling between the stages. This method of compression is called multistage compression.

## Thermal Engineering

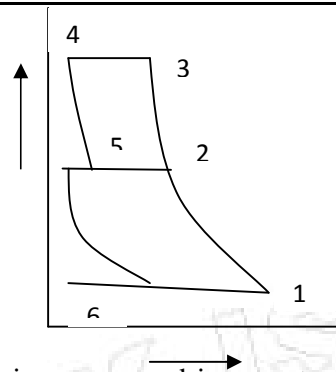

If the air is compressed in one stage the gas in clearance space would expand to a larger volume during its inlet stroke which results in a low volumetric efficiency. Therefore, in multistage compression with intercooling between the stages a high volumetric efficiency can be achieved.

In multistage compression a smooth torque angle diagram is obtained. Hence, a smaller flywheel is needed.

The exhaust temperature of air after multistage is low compared to single stage compression. This reduces the lubrication problems and the mean cylinder wall temperature.

Less leakage problems are faced due to the reduced pressure difference for each stage.

d. *Advantages of high pressure boiler*

- Ans: 1. In high pressure boilers pumps are used to maintain forced circulation of water through the tubes of the boiler. This ensures positive circulation of water and increases evaporative capacity of boiler and less number of steam drums will be required.
2. The heat of combustion is utilized more efficiently by the use of small diameter tube in large number and in multiple circuits.
3. Pressurized combustion is used which increases rate of firing of fuel thus increasing the rate of heat release.
4. Due to compactness less floor space is required.
5. The tendency of scale formation is eliminated due to high velocity of water through the tubes.

e. *Need of air motor in condenser.*

Ans: The function of which an air pump performs is that it maintains vacuum in the condenser as nearly as possible equal to that corresponding to the exhaust steam temperature by removing air from the condenser.

It may also remove condensate together with air from the condenser.

An air pump which removes the moist air alone is called a dry air pump whereas that which removes both air and condensate is called wet air pump.

## Thermal Engineering

f. *Condition for maximum discharge through nozzle.*

Ans: The maximum discharge per unit area can be obtained by substituting critical pressure ratio in expression for mass flow per unit area at throat section.

$$\begin{aligned}\frac{m'}{A_t} &= \sqrt{2 \left( \frac{n}{n-1} \right) \cdot \frac{p_1}{v_1} \left\{ \left( \frac{2}{n+1} \right)^{\frac{2}{(n-1)}} - \left( \frac{2}{n+1} \right)^{\frac{(n+1)}{(n-1)}} \right\}} \\ \frac{m'}{A_t} &= \left[ \left( \frac{2n}{n-1} \right) \cdot \frac{p_1}{v_1} \left( \frac{2}{n+1} \right)^{\frac{(n+1)}{(n-1)}} \cdot \left\{ \left( \frac{2}{n+1} \right)^{\frac{(1-n)}{(n-1)}} - 1 \right\} \right]^{1/2} \\ &= \left[ \left( \frac{2n}{n-1} \right) \cdot \frac{p_1}{v_1} \left( \frac{2}{n+1} \right)^{\frac{(n+1)}{(n-1)}} \cdot \left\{ \frac{n+1}{2} - 1 \right\} \right]^{1/2} \\ \frac{m'}{A_t} &= \left[ n \cdot \frac{p_1}{v_1} \left( \frac{2}{n+1} \right)^{\frac{(n+1)}{(n-1)}} \right]^{1/2}\end{aligned}$$

$$\text{Maximum discharge per unit area} = \sqrt{n \cdot \frac{p_1}{v_1} \left( \frac{2}{n+1} \right)^{\frac{(n+1)}{(n-1)}}}$$

For this maximum discharge per unit area at throat the velocity at throat can be obtained for critical pressure ratio. This velocity may also be termed as 'critical velocity'.

$$C_2 = \sqrt{2 \left( \frac{n}{n-1} \right) (p_1 v_1 - p_2 v_2)}$$

At throat

$$C_t = \sqrt{2 \left( \frac{n}{n-1} \right) p_t v_t \left( \frac{p_t v_t}{p_t v_t} - 1 \right)}$$

$$C_t = \sqrt{2 \left( \frac{n}{n-1} \right) \cdot p_t v_t \left\{ \left( \frac{p_t}{p_1} \right)^{\frac{(1-n)}{n}} - 1 \right\}}$$

Substituting critical pressure ratio  $\left( \frac{p_t}{p_1} \right)$

$$C_t = \sqrt{2 \left( \frac{n}{n-1} \right) \cdot p_t v_t \left\{ \left( \frac{n+1}{2} \right) - 1 \right\}}$$

$$C_t = \sqrt{n p_t v_t} \quad \text{Hence, critical velocity} = \sqrt{n p_t v_t}$$

For perfect gas;  $C_t = \sqrt{n \cdot R T_t}$

For  $n = \gamma$ ,  $C_t = \sqrt{\gamma R T_t} = a = \text{Velocity of sound.}$

Thus it can be concluded that for maximum discharge per unit area at throat the fluid velocity (critical velocity) equals to the sonic velocity. At the throat section mach no.  $M = 1$  for critical pressure ratio.

## Thermal Engineering

i. **Enthalpy of combustion:-**

If work transfer is zero i.e.  $W_c=0$ , then heat of reaction at specific pressure and temperature. Heat of reaction at standard state is denoted by  $\bar{h}_{12}^o$ . Enthalpy of reaction for a combustion process is called the enthalpy of combustion  $\Delta h_r$  which equals to negative value of  $\dot{Q}_r$ .

ii. **Enthalpy of formation:-**

The enthalpy of formation ( $H_f$ ) is the increase in enthalpy when a compound is formed from its constituent elements when a compound is formed from its constituent elements in their natural form and in a standard state.

iii. **Stoichiometric air fuel ratio:-**

Stoichiometric ( or chemically correct) mixture of air and fuel is one that contains just sufficient oxygen for complete combustion of fuel.

iv. **Importance of adiabatic flame temperature:-**

In a given combustion process, that takes place adiabatically and with no work or changes in kinetic or potential energy involved, the temperature of the products is referred to as the 'adiabatic flame temperature'.

Q.2b. **Liquid octane  $C_8H_{18}$  at  $25^\circ C$  is used as fuel. Air used is 150% of theoretical air and is supplied at  $25^\circ C$ . Assume a complete combustion and the product leaves the combustion chamber at  $1500K$ . Calculate the heat transfer per kg mole of fuel. Use the following data:-**

Substance	$h_f^o$ (MJ/k-mol)	$h_{298K}$ (MJ/k-mol)	$h_{1500K}$ (MJ/k-mol)
$C_8H_{18}(liq.)$	-250	-	-
$O_2$	-	8.68	49.29
$N_2$	-	8.67	47.07
$H_2O(gas)$	-241.8	9.90	57.99
$CO_2$	-393.5	9.36	71.078

Ans: Combustion reaction for Liquid Octane.



$$\dot{Q} - \dot{W} = (H_P - H_R) \quad \because \dot{W} = 0$$

As 150% Thepretical air is supplied at  $25^\circ C$

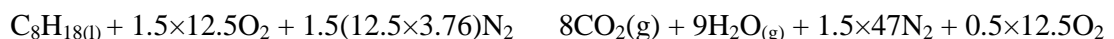

## Thermal Engineering

$$= -1436.63 \text{ KJ/kg}_{\text{mole}} \text{ of fuel.}$$

$$= 3218.637 \text{ KJ/kg}_{\text{mole}} .$$

$$Q = H_P - H_R$$

$$= -1782.007 \text{ KJ/kg}_{\text{mole}}$$

$$\text{Heat transferred per kg mole} = -1782.007 \text{ KJ/kg}_{\text{mole}}$$

Q.2c. **Vaccum Efficiency of condenser.**

4

Ans: The ratio of actual vaccum to ideal vaccum in the condenser is defined as the vaccum efficiency.

∴ Vaccum Efficiency

$P_t$  = Actual absolute pressure in the condenser

$$= p_s + p_a$$

$P_s$  = Saturation pressure of steam corresponding to its saturation temperature

## Thermal Engineering

P= barometric pressure.

Q.3a. *Derive ideal intercooling pressure ratio (with perfect intercooling) for minimum work output of compressor.*

8

Ans: Equation for workdone with perfect intercooling is

$$W_C = \left( \frac{n}{n-1} \right) P_1 V_1 \left[ \left( \frac{P_2}{P_1} \right)^{\frac{n-1}{n}} + \left( \frac{P_2'}{P_1} \right)^{\frac{n-1}{n}} - 2 \right]$$

For minimum work differentiating above w.r.to  $P_2$

$$\frac{dW_C}{dP_2} = \frac{d}{dP_2} \left[ \left( \frac{n}{n-1} \right) P_1 V_1 \left\{ \left( \frac{P_2}{P_1} \right)^{\frac{n-1}{n}} + \left( \frac{P_2'}{P_1} \right)^{\frac{n-1}{n}} - 2 \right\} \right]$$

$$\frac{dW_C}{dP_2} = \left( \frac{n}{n-1} \right) P_1 V_1 \left\{ \left( \frac{n-1}{n} \right) P_1^{\frac{1-n}{n}} \cdot P_2^{\frac{-1}{n}} - \left( \frac{n-1}{n} \right) \cdot P_2'^{\frac{1-n}{n}} \cdot P_2^{\frac{1-2n}{n}} \right\}$$

Equating to zero yields

$$P_1^{\frac{1-n}{n}} \cdot P_2^{\frac{-1}{n}} = P_2'^{\frac{1-n}{n}} \cdot P_2^{\frac{1-2n}{n}}$$

$$P_2^{\frac{-2+2n}{n}} = P_2'^{\frac{1-n}{n}} \cdot P_1^{\frac{n-1}{n}}$$

$$P_2^{2\left(\frac{n-1}{n}\right)} = (P_1 \cdot P_2')^{\left(\frac{n-1}{n}\right)}$$

$$P_2^2 = (P_1 \cdot P_2') P_2 = \sqrt{P_1 \cdot P_2'}$$

## Thermal Engineering

$P_2$  obtained from above equation will give ideal intermediate pressure which, with perfect intercooling, will give the minimum W.

Q.3.b. A two stage single acting reciprocating compressor takes in air at the rate of  $0.2 \text{ m}^3/\text{s}$ . The air is compressed to a final pressure of  $0.7 \text{ MPa}$ . The intermediate pressure is ideal and intercooling is perfect. The compression index in both the stages is  $1.25$  and the compressor runs at  $600 \text{ r.p.m}$ . Neglecting clearance, determine:- 12

- (i) Intermediate pressure
- (ii) The total volume of each cylinder
- (iii) The power required to drive the compressor
- (iv) The rate of heat rejection in the intercooler

Ans: Intake volume,  $v_1 = 0.2 \text{ m}^3/\text{s}$

Intake pressure,  $p_1 = 0.1 \text{ MPa}$

Intake temperature,  $T_1 = 16 + 273 = 289 \text{ K}$

Final pressure,  $p_3 = 0.7 \text{ MPa}$

Compression index in both stages  $n_1 = n_2 = n = 1.25$

Speed of the compressor,  $N = 600 \text{ r.p.m}$ .

$C_p = 1.005 \text{ kJ/kgK}$ ,  $R = 0.287 \text{ kJ/kgK}$

- i. The intermediate pressure  $p_2$ :

$$P_2^2 = (P_1 \cdot P_3) \quad P_2 = \sqrt{P_1 \cdot P_3}$$

$$P_2 = 0.2646 \text{ MPa}$$

- ii. The total volume of each cylinder,  $v_{s1}$ ,  $v_{s2}$ :

We know that —

$$v_{s1} \text{ (Volume of L.P.cylinder)} = 0.02 \text{ m}^3$$

Also

$$v_{s2} \text{ (Volume of H.P.cylinder)} = 0.00756 \text{ m}^3$$

- iii. The power required to drive the compressor, P

$$P = \left( \frac{2n}{n-1} \right) (p_1 V_1) \left[ \left( \frac{p_3}{p_1} \right)^{\frac{n-1}{n}} - 1 \right]$$

$$= 42.96 \text{ kW}$$

Thermal Engineering

iv. The rate of heat rejection in the intercooler

Mass of air handled, —  
 = 0.241 kg/s

Also  $\left(\frac{p_2}{p_1}\right)^{\frac{n-1}{n}} = \frac{T_2}{T_1}$

$T_2 = 351.1\text{K}$

Therefore heat rejected in the intercooler =  $mc_p(T_2 - T_1)$   
 = 15.04 kW

Q.4.a. Prove  $t$  at the optimum blade speed ratio ( ) for single impulse turbine for maximum efficiency

is given by: —, where = Nozzle angle.

Ans: The velocity diagram for a single-stage impulse has been shown in Fig. shows the velocity diagram indicating the flow through the turbine blades.

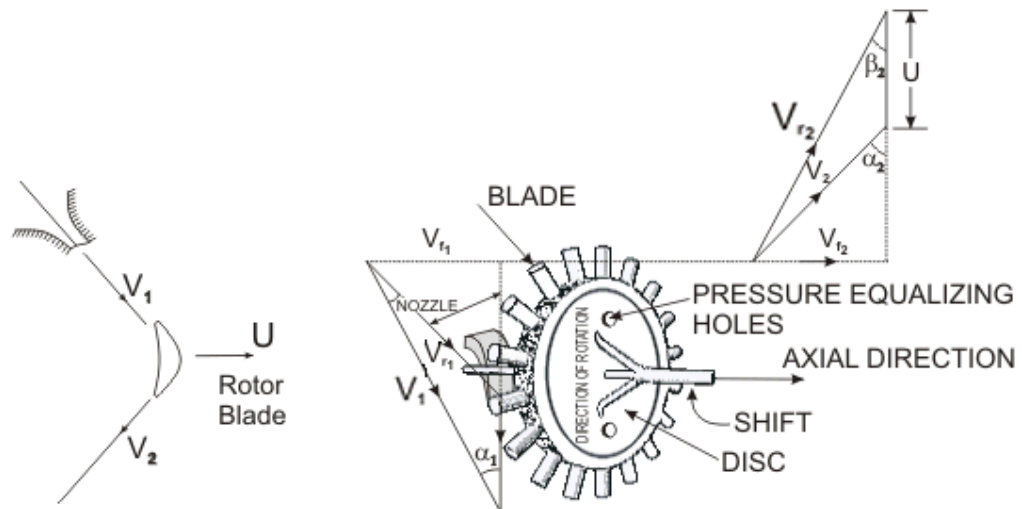

and = Inlet and outlet absolute velocity

and = Inlet and outlet relative velocity (Velocity relative to the rotor blades.)

Thermal Engineering

$U$  = mean blade speed

$\alpha_1$  = nozzle angle,  $\alpha_2$  = absolute fluid angle at outlet

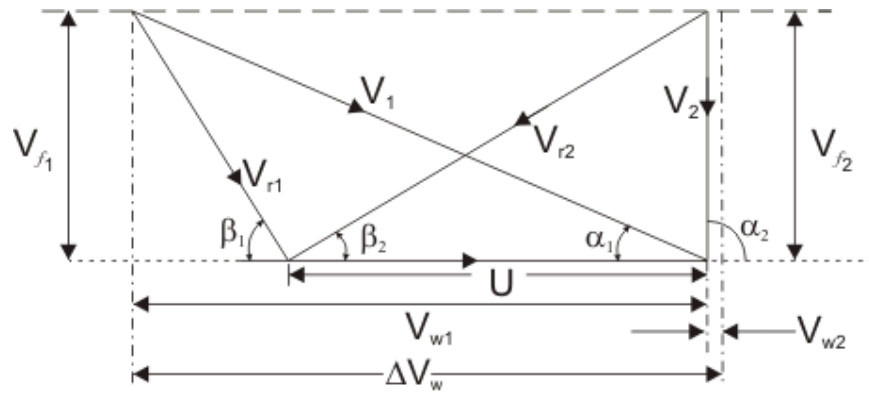

and  $\beta_1, \beta_2$  = Inlet and outlet **blade angles**

and  $V_{f1}, V_{f2}$  = Tangential or whirl component of absolute velocity at inlet and outlet

and  $V_{w1}, V_{w2}$  = Axial component of velocity at inlet and outlet

Tangential force on a blade,

$$F_t = \dot{m} (\Delta V_w)$$

(mass flow rate X change in velocity in tangential direction)

or,

$$F_t = \dot{m} U \frac{\Delta V_w}{U}$$

Power developed =  $F_t U$

Blade efficiency or Diagram efficiency or Utilization factor is given by

$$\eta = \frac{\text{Power developed}}{\dot{m} U^2} = \frac{\dot{m} U \Delta V_w}{\dot{m} U^2} = \frac{\Delta V_w}{U}$$

or,

and  $\beta_1, \beta_2$  = Inlet and outlet **blade angles**

Thermal Engineering

---

and = Tangential or whirl component of absolute velocity at inlet  
and outlet

and = Axial component of velocity at inlet and outlet

Tangential force on a blade,

$$- \quad -$$

(mass flow rate X change in velocity in tangential direction)

or, =

Power developed =

Blade efficiency or Diagram efficiency or Utilization factor is given by

$$= \frac{\dots}{\dots} =$$

$$= \frac{\dots}{\dots}$$

or,

stage efficiency = =  $\frac{\dots}{\dots}$

$$\frac{\dots}{\dots} = \frac{\dots}{\dots}$$

or,

or, = =

Optimum blade speed of a single stage turbine

$$=$$

Thermal Engineering

$$= \frac{1}{2} \rho C_d A V^2$$

$$= \frac{1}{2} \rho C_d A V^2$$

where,  $C_d$  = friction coefficient

$$=$$

$$\frac{1}{2} \rho C_d A V^2 = \frac{1}{2} \rho C_d A V^2$$

$$= \frac{1}{2} \rho C_d A V^2$$

= Blade speed ratio

is maximum when  $\frac{1}{2} \rho C_d A V^2 = \frac{1}{2} \rho C_d A V^2$  also  $\frac{1}{2} \rho C_d A V^2 = \frac{1}{2} \rho C_d A V^2$

or,  $\frac{1}{2} \rho C_d A V^2 = \frac{1}{2} \rho C_d A V^2$

or,  $\frac{1}{2} \rho C_d A V^2 = \frac{1}{2} \rho C_d A V^2$

Q.4.b. The following data refer to boiler plant consisting of an economizer, a boiler and a superheater:- 12

- Mass of water evaporated per hour = 5940 kg,
- Mass of coal burnt per hour = 675kg
- Lower calorific value of coal = 31600 kJ/kg
- Pressure of steam at boiler stop valve = 14 bar,
- Temperature of feed water entering the economizer = 32°C
- Temperature of feed water leaving the economizer = 115°C
- Dryness fraction of steam leaving the boiler and entering the superheater = 0.96,
- Temperature of feed steam leaving the superheater = 260°C,
- Considering specific heat of superheated steam = 2.33,

Calculate:

- i. Percentage of heat in coal utilized in economizer, superheater and boiler
- ii. Overall efficiency of boiler plant

Ans: Given data

## Thermal Engineering

Mass of water evaporated = 5940 kg/hr

Mass of coal burnt = 675 kg/hr

L.C.V. of coal = 31600 kJ/kg

Pressure of steam at boiler stop valve =  $p_1=14$  bar

Heat utilized by 1kg of feed water in economizer

$$h_{f1} = 1 \times 4.18 \times (t_{e2} - t_{e1})$$

$$= 346.9 \text{ kJ/kg}$$

Heat utilized in boiler per kg of feed water

$$h_{\text{boiler}} = (h_f + x h_{fg}) - h_{f1}$$

At 14 bar pressure, from steam tables,

$$t_s = 195^\circ\text{C}, h_f = 830.1 \text{ kJ/kg}, h_{fg} = 1957.7 \text{ kJ/kg}$$

$$h_{\text{boiler}} = 2362.6 \text{ kJ/kg}$$

Heat utilized in superheater by 1kg of feed water,

$$h_{\text{superheater}} = (1-x)h_{fg} + C_p(T_{\text{sup}} - T_s)$$

$$= 227.8 \text{ kJ/kg}$$

Also, mass of water evaporated / hour / kg of coal burnt

$$= 5940/675 = 8.8 \text{ kg.}$$

i. Percentage of heat utilized in economizer

$$= (346.9/31600) \times 8.8 \times 100$$

$$= 9.66\%$$

Percentage of heat utilized in boiler

$$= (2362.6/31600) \times 8.8 \times 100$$

$$= 65.7\%$$

Percentage of heat utilized in superheater

$$= (227.8/31600) \times 8.8 \times 100$$

$$= 6.34\%$$

ii. Overall efficiency of boiler plant, overall:

Total heat absorbed in kg of water

$$= h_{f1} + h_{\text{boiler}} + h_{\text{superheater}}$$

$$= 2937.3 \text{ kJ/kg}$$



Thermal Engineering

Given:  $T_1=15+273=288K$

Pressure ratio, — —

compressor=82%

Effectiveness of the heat exchanger, =0.78

turbine=82%

Maximum temperature,  $T_3= 600+273$   
 $= 873K$

Efficiency of the cycle cycle:

Considering the isentropic compression 1-2, we have

— — — —

$T_2= 288 \times 1.486$   
 $= 428 K$

Now,

$T_2= 459K$

Considering the isentropic expansion process 3-4, we have

— — — —

$T_4= 587.5K$

Again

## Thermal Engineering

$$T_4' = 673 \text{ K}$$

But

$$\begin{aligned} \text{Net Work} &= W_{\text{turbine}} - W_{\text{compressor}} \\ &= 29.2 \text{ kJ/kg} \end{aligned}$$

Effectiveness of heat exchanger

$$T_5 = 626 \text{ K}$$

Heat supplied by fuel per kg

$$\begin{aligned} &= C_p(T_3 - T_5) \\ &= 248.1 \text{ kJ/kg} \end{aligned}$$

---

 Thermal Engineering
 

---

Q.6.a. *Discuss velocity and pressure compounding for steam turbine with neat sketch.*

8

Ans: **The Velocity - Compounding of the Impulse Turbine**

The velocity-compounded impulse turbine was first proposed by C.G. Curtis to solve the problems of a single-stage impulse turbine for use with high pressure and temperature steam. The *Curtis stage* turbine, as it came to be called, is composed of one stage of nozzles as the single-stage turbine, followed by two rows of moving blades instead of one. These two rows are separated by one row of fixed blades attached to the turbine stator, which has the function of redirecting the steam leaving the first row of moving blades to the second row of moving blades. A Curtis stage impulse turbine is shown in Fig. with schematic pressure and absolute steam-velocity changes through the stage. In the Curtis stage, the total enthalpy drop and hence pressure drop occur in the nozzles so that the pressure remains constant in all three rows of blades.

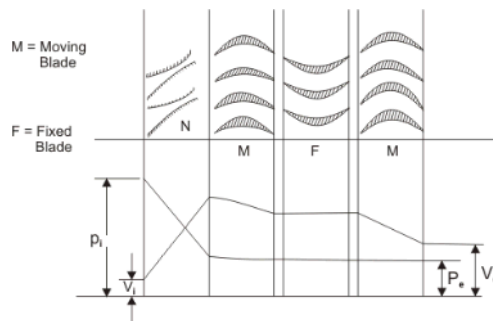

### Velocity Compounding arrangement

Velocity is absorbed in two stages. In fixed (static) blade passage both pressure and velocity remain constant. Fixed blades are also called guide vanes. Velocity compounded stage is also called **Curtis stage**. The velocity diagram of the velocity-compound Impulse turbine is shown in Figure.

Thermal Engineering

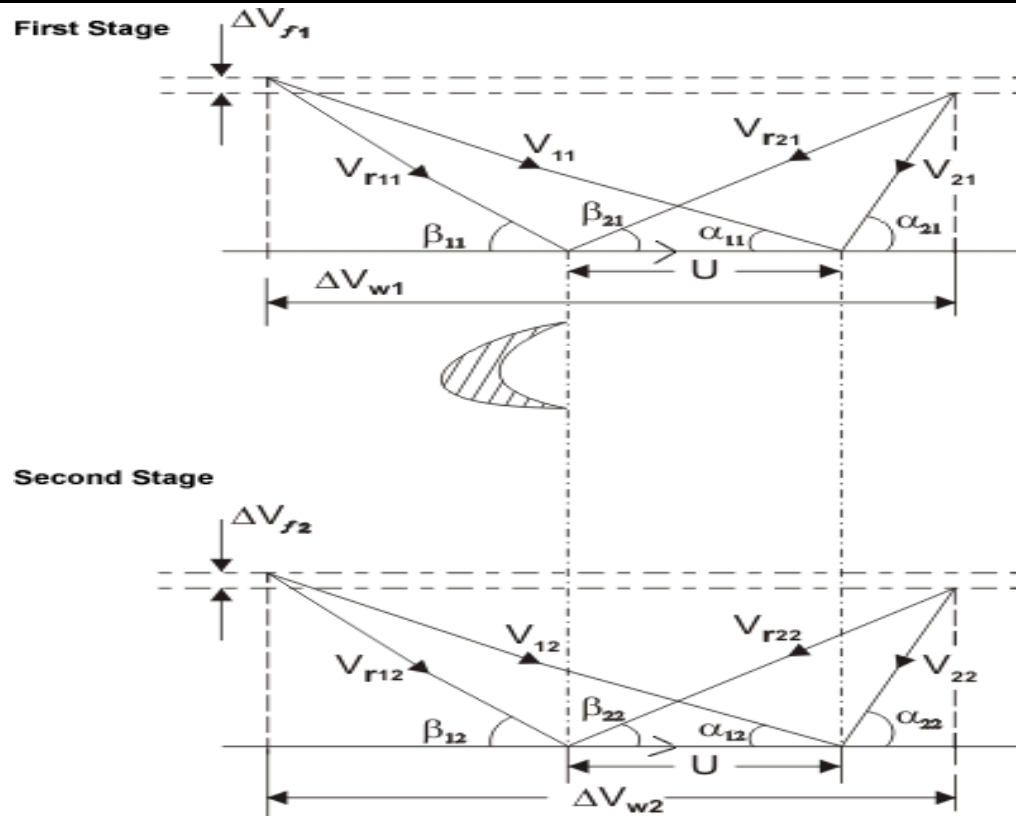

**Velocity diagrams for the Velocity-Compounded Impulse turbine**

The fixed blades are used to guide the outlet steam/gas from the previous stage in such a manner so as to smooth entry at the next stage is ensured.

K, the blade velocity coefficient may be different in each row of blades

**Work done =**

**End thrust =**

= \_\_\_\_\_

The optimum velocity ratio will depend on number of stages and is given by

- Work is not uniformly distributed (1st > 2nd)
- The first stage in a large (power plant) turbine is velocity or pressure compounded impulse stage.

**Pressure Compounding or Rateau Staging -**

Thermal Engineering

**The Pressure - Compounded Impulse Turbine**

To alleviate the problem of high blade velocity in the single-stage impulse turbine, the total enthalpy drop through the nozzles of that turbine are simply divided up, essentially in an equal manner, among many single-stage impulse turbines in series (Figure). Such a turbine is called a *Rateauturbine* , after its inventor. Thus the inlet steam velocities to each stage are essentially equal and due to a reduced  $h$ .

**Pressure-Compounded Impulse Turbine**

**Pressure drop** - takes place in more than one row of nozzles and the increase in kinetic energy after each nozzle is held within limits. Usually convergent nozzles are used

We can write

$$\begin{aligned}
 & \text{---} = \text{---} \\
 & = \frac{\text{---}}{\text{---}}
 \end{aligned}$$

where  $\text{---}$  is carry over coefficient

Q.6.b. *A stage of a turbine with parson blading delivers dry saturated steam at 2.7 bar from the fixed blade at 90 m/s. The mean blade height is 40 mm and the moving blade exit angle is*

Thermal Engineering

$20^\circ$ . The axial velocity of steam is three fourth of the blade velocity at the mean radius. Steam is supplied at the stage at the rate of 9000kg/h. Calculate:-

- i. The wheel speed in rpm
- ii. The diagram power
- iii. The diagram efficiency
- iv. The enthalpy drop of steam in stage

12

Ans:

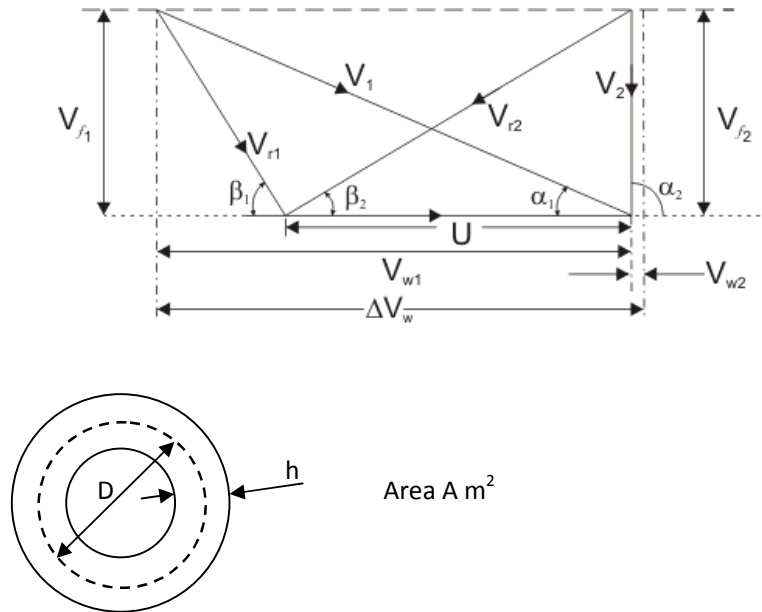

The velocity diagram is shown in first figure and the blade wheel annulus is represented in second figure

Pressure = 2.7 bar,  $x=1$

$V_1 = 90 \text{ m/s}$ ,  $h = 40 \text{ mm} = 0.04 \text{ m}$

$$\alpha_1 = \alpha_2 = 20^\circ, V_{f1} = V_{f2} = \frac{3}{4} V_{bl}$$

Rate of Steam supply = 9000kg/h

- i. Wheel speed  $N$ :  
 $V_f = \frac{3}{4} V_{bl} = V_1 \sin 20$

$$= 30.78 \text{ m/s}$$

$$V_{bl} = 41.04 \text{ m/s}$$

The mass flow rate of steam is given by,

—

Where  $A$  is the annulus area and  $v$  is the specific volume of the steam.

Thermal Engineering

---

In this case  $v_g$  at 2.7 bar = 0.6686 m<sup>3</sup>/kg

$A=0.054 \text{ m}^2$

ii. \_\_\_\_\_

iii. Enthalpy drop in the stage: \_\_\_\_\_

Total enthalpy drop per stage=  $2 \times 2.63 = 5.26 \text{ kJ/kg}$

Q.7 Write short notes on any four of the following:-

20

a. *Effect of intercooling, reheating and regeneration on the efficiency and work output of gas turbine.*

Ans:

**Simple Cycle with Exhaust Heat Exchange  
CBTX Cycle (Regenerative) cycle)**

In most cases the turbine exhaust temperature is higher than the outlet temperature from the compressor. Thus the exhaust heat can be utilised by providing a heat exchanger that reduces heat input in the combustion chamber. This saving of energy increases the efficiency of the regeneration cycle keeping the specific output unchanged. A regenerative cycle is illustrated in Figure.

Thermal Engineering

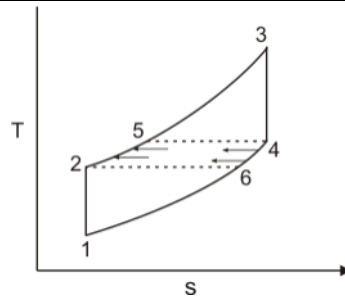

for heat exchange to take place

We assume ideal exchange = and =

**Simple gas turbine cycle with heat exchange**

With ideal heat exchange, the cycle efficiency can be expressed as,

$$\eta = \frac{T_3 - T_4}{T_3 - T_2} - \frac{T_5 - T_6}{T_5 - T_4}$$

$$= \frac{T_3 - T_4}{T_3 - T_2} - \frac{T_4 - T_1}{T_5 - T_4}$$

$$= \frac{T_3 - T_4}{T_3 - T_2} - \frac{T_4 - T_1}{T_4 - T_1} = 1 - \frac{T_4 - T_1}{T_3 - T_2}$$

or,

$$\eta = 1 - \frac{T_4 - T_1}{T_3 - T_2}$$

- Efficiency is more than that of simple cycle
- With heat exchange (ideal) the specific output does not change but the efficiency is increased

**Gas Turbine Cycle with Reheat**

A common method of increasing the mean temperature of heat reception is to reheat the gas after it has expanded in a part of the gas turbine. By doing so the mean temperature of heat rejection is also increased, resulting in a decrease in the thermal efficiency of the plant. However, the specific output of the plant increases due to reheat. A reheat cycle gas turbine plant is shown in Figure.

**Reheat cycle gas turbine plant**

The specific work output is given by,

Thermal Engineering

$$= \dots$$

The heat supplied to the cycle is

$$= \dots$$

Thus, the cycle efficiency,

$$= \dots$$

Therefore, a reheat cycle is used to increase the work output while a regenerative cycle is used to enhance the efficiency.

**Gas Turbine Cycle with Inter-cooling**

The cooling of air between two stages of compression is known as intercooling. This reduces the work of compression and increases the specific output of the plant with a decrease in the thermal efficiency. The loss in efficiency due to intercooling can be remedied by employing exhaust heat exchange as in the reheat cycle.

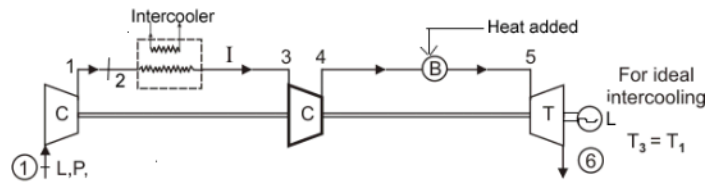

**Specific work output** =  $\dots$

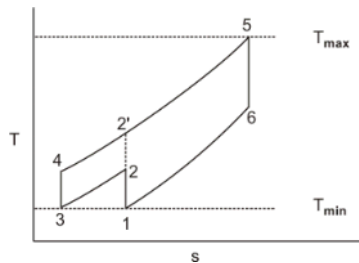

Heat supplied =  $\dots$

If  $\dots$  is constant and not dependent on temperature, we can write:

$$= \dots$$

## Thermal Engineering

**Note**

Here heat supply and output both increases as compared to simple cycle. Because the increase in heat supply is proportionally more, decreases.

b. *Condition of maximum discharge through nozzle.*

Ans: The maximum discharge per unit area can be obtained by substituting critical pressure ratio in expression for mass flow per unit area at throat section.

For this maximum discharge per unit area at throat the velocity at throat can be obtained for critical pressure ratio. This velocity may also be termed as 'critical velocity'.

$$C_2 = \sqrt{2 \left( \frac{n}{n-1} \right) (p_1 v_1 - p_2 v_2)}$$

At throat

$$C_t = \sqrt{2 \left( \frac{n}{n-1} \right) p_t v_t \left( \frac{p_t v_t}{p_t v_t} - 1 \right)}$$

$$C_t = \sqrt{2 \left( \frac{n}{n-1} \right) \cdot p_t v_t \left[ \left( \frac{p_t}{p_1} \right)^{\frac{(1-n)}{n}} - 1 \right]}$$

Substituting critical pressure ratio  $\left( \frac{p_t}{p_1} \right)$

$$C_t = \sqrt{2 \left( \frac{n}{n-1} \right) \cdot p_t v_t \left[ \left( \frac{n+1}{2} \right) - 1 \right]}$$

$$C_t = \sqrt{n p_t v_t} \quad \text{Hence, critical velocity} = \sqrt{n \cdot p_t \cdot v_t}$$

For perfect gas:  $C_t = \sqrt{n \cdot R T_t}$

For  $n = \gamma$ ,  $C_t = \sqrt{\gamma R T_t} = a = \text{Velocity of sound.}$

## Thermal Engineering

Thus it can be concluded that for maximum discharge per unit area at throat the fluid velocity (critical velocity) equals to the sonic velocity. At the throat section mach no.  $M = 1$  for critical pressure ratio.

### c. Describe Benson Boiler

Ans: It is a water tube boiler capable of generating steam at supercritical pressure. Figure shows the schematic of Benson boiler. Mark benson, 1992 conceived the idea of generating steam at supercritical pressure in which water flashes into vapour without any latent heat requirement. Above critical point the water transforms into steam in the absence of boiling and without any change in volume i.e. same density. Contrary to the bubble formation on tube surface impairing heat transfer in the normal pressure boilers, the supercritical steam generation does not have bubble formation and pulsations etc. due to it. Steam generation also occurs very quickly in these boilers. As the pressure and temperatures have to be more than critical point, so material of construction should be strong enough to withstand thermal stresses. Feed pump has to be of large capacity as pressure inside is quite high, which also lowers the plant efficiency due to large negative work requirement. Benson boilers generally have steam generation pressure more than critical pressure and steaming rate of about 130–135 tons/hr. Thermal efficiency of these boilers is of the order of 90%.

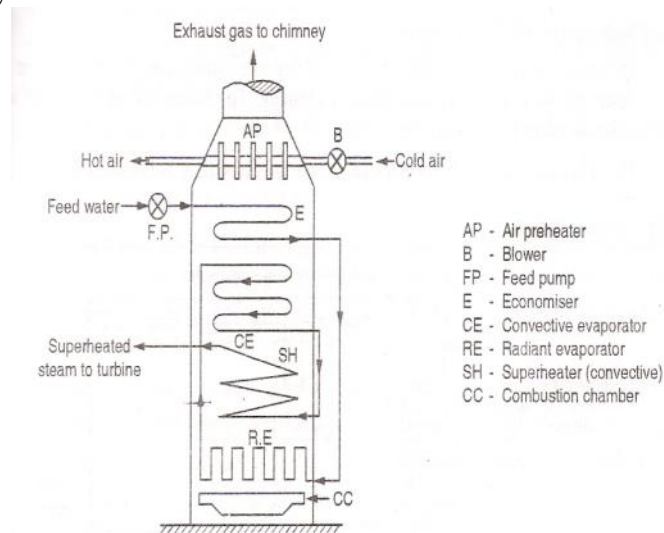

### d. Condition for maximum efficiency in case reaction turbine

Ans:- A very widely used design has half degree of reaction or 50% reaction and this is known as Parson's Turbine. This consists of symmetrical stator and rotor blades.

Thermal Engineering

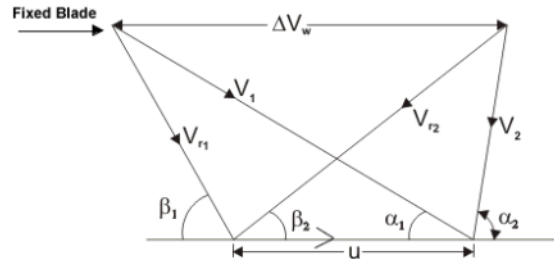

**The velocity diagram of reaction blading**

The velocity triangles are symmetrical and we have

$$= \quad =$$

$$= \quad =$$

Energy input per stage (unit mass flow per second)

$$= U \quad -$$

$$- \quad -$$

$$= \quad - \quad - \quad - \quad -$$

$$=$$

From the inlet velocity triangle we have,

$$= \quad - \quad -$$

Work done (for unit mass flow per second)  $- \quad -$

$$= \quad -$$

Therefore, the Blade efficiency

$$= \quad = \frac{\quad -}{\quad -}$$

Reaction Turbine, Continued

Put

-

Thermal Engineering

---

then

$$= \frac{u}{c} \left( \frac{c}{u} \right)$$

For the maximum efficiency  $\frac{u}{c} = \frac{1}{2}$  and we get

$$\eta = \frac{2u}{c} \left( \frac{c}{u} \right) \left( \frac{c}{u} \right) = \frac{2u}{c} \left( \frac{c}{u} \right)^2 = \frac{2u}{c} \left( \frac{c^2}{u^2} \right) = \frac{2c}{u}$$

from which finally it yields

$$= \frac{2c}{u} = \frac{2}{\frac{u}{c}} = \frac{2}{\frac{1}{2}} = 4$$

**Velocity diagram for maximum efficiency**

Absolute velocity of the outlet at this stage is axial (see figure). In this case, the energy transfer

$$= \frac{2u}{c}$$

can be found out by putting the value of  $\frac{u}{c} = \frac{1}{2}$  in the expression for blade efficiency

$$= \frac{2u}{c}$$

$$=$$

is greater in reaction turbine. Energy input per stage is less, so there are more number of stages.

- e. **Boiler mounting and accessories**

## Thermal Engineering

Ans: Devices which are mounted on boiler for its control and safe operation are called “mountings” while devices which are mounted on boiler for improving its performance are called “accessories”. Thus boiler mountings are necessary while boiler accessories are optional.

Different mountings are

- (i) Water level indicator
- (ii) Safety valves
- (iii) High steam and low water safety valves
- (iv) Fusible plug
- (v) Pressure gauge
- (vi) Stop valve
- (vii) Feed check valve
- (viii) Blow off cock
- (ix) Manhole and mud box

Various boiler accessories are:

- (i) Superheater
- (ii) Economiser
- (iii) Air preheater
- (iv) Feed pump

f. **Difference between fire tube and water tube boiler.**

Ans:

	<b><i>Fire tube boiler</i></b>	<b><i>Water tube boiler</i></b>
i.	In this the hot flue gases flow in the tubes surrounded outside by the water.	In this the water flows in the tubes surrounded outside by the hot gases.
ii.	These boilers have large water to steam ratio and therefore	It has comparatively lower water to steam ratio, therefore,
a.	These are slower in operation and have low evaporation rates.	a. It helps in reaching the steam temperature in a shorter time thereby increasing the evaporation rate.
b.	Temperature stresses causing the failure of feed water arrangement is minimum.	b. It is subjected to temperature stresses due to failure of feed water arrangement.
iii.	It can work only upto 20 bar pressure because of larger drum diameters and the limitations of the boiler shell thickness and stress considerations.	Because of smaller drum diameter it can withstand higher internal pressures for the same limit of thickness and stress therefore, these boilers are suitable for higher pressure operation upto 200 bar.
iv.	It has a simple and rigid construction with low cost but	It has complex design with high initial cost but has lesser

Thermal Engineering

- |       |  |   |
|-------|--|---|
|       | more maintenance and operation cost.   | maintenance and operation cost.   |
| v.    | These are made in smaller sizes and these are not suitable for large power houses.                 | These are bigger in sizes and are suitable for large power plants.  |
| vi.   | Transportation and installation of the boiler is difficult because of the large size of the shell. | It is easy to transport and install since its various parts can be dismantled easily and they can be reassembled at site. |
| vii.  | The furnace design is rigid. Therefore the particular type of fuel can only be used.               | These boilers are mostly externally fired. The proportions of the furnace can be varied to suit the fuel reaction.        |
| viii. | It requires less floor area.   | It requires more floor area.  |

