

MACHINE DRAWING

Q.No.1.

a. Figure shows the F.V. and LHSV Draw the following to the scale:

i) F.V. and L.H.S.V

ii) Complete T. V.

iii) Auxiliary view from the direction of arrow 'X'

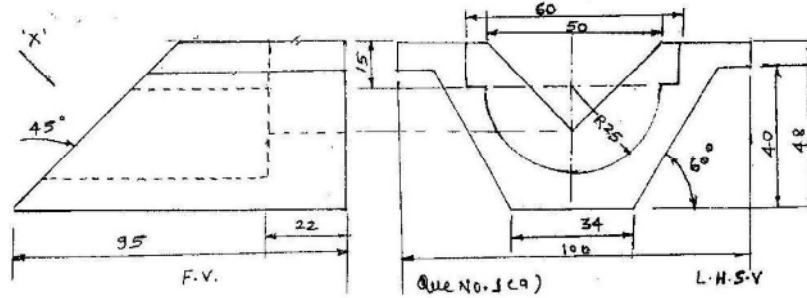

Ans:

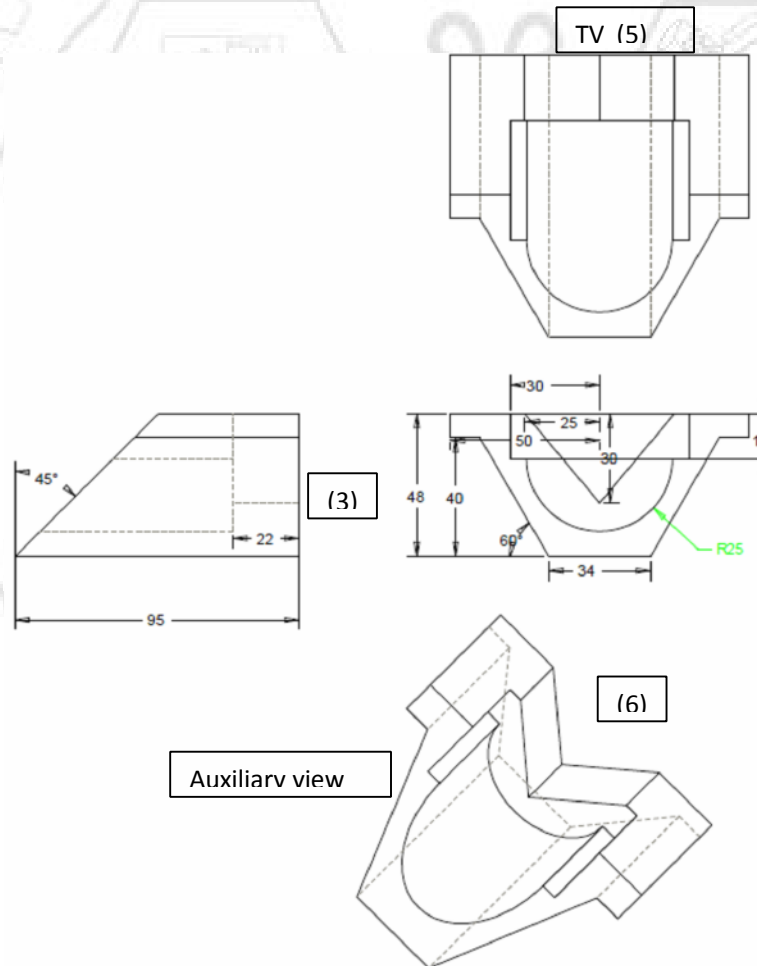

MACHINE DRAWING

b) Define the term with suitable sketches

1) Tolerance Zone

2) Upper and Lower deviation

3) Allowances

Ans:

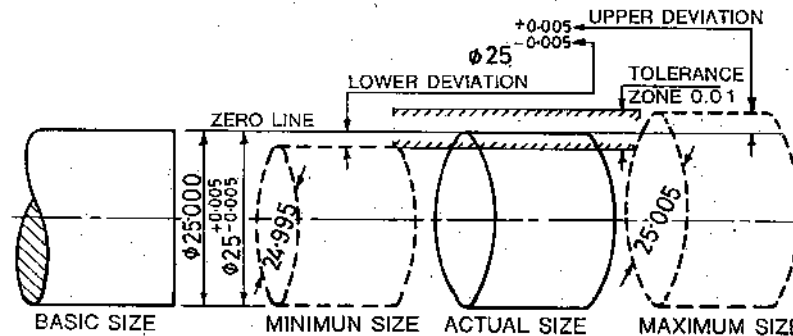

i) Tolerance zone: It is an algebraic difference between the maximum limit and minimum limit.

$$\text{Tolerance zone} = \text{Maximum Limit} - \text{Minimum Limit} = 25.05 - 24.95 = 0.1 \text{ mm}$$

$$\text{or} = \text{Upper Deviation} - \text{Lower Deviation}$$

$$= 0.05 - (-0.05) = 0.10 \text{ mm.}$$

2

ii) 1) Upper deviation: It is an algebraic difference between the maximum size and basic size.

$$\text{Upper deviation} = \text{Maximum Limit} - \text{Basic size.}$$

Consider that in the above fig, the maximum limit is 25.05 mm and minimum limit is 24.95 mm then

$$\text{Upper deviation} = 25.05 - 25.00 = 0.05 \text{ mm.}$$

2

2) Lower deviation: It is an algebraic difference between minimum limit and the basic size.

$$\text{Lower deviation} = \text{Minimum Limit} - \text{Basic size}$$

$$= 24.95 - 25.00$$

$$\text{Lower deviation} = -0.05 \text{ mm.}$$

iii) Allowance: It is an intentional difference between the maximum material limits of mating parts.

2

Eg. Draft allowances, expansion allowances.

MACHINE DRAWING

Q2. Figure shows Simple Eccentric. Draw the following

(a) Upper Strap:

i) Sectional Front View

ii) Right Hand Side View

iii) Top View

(b) Sheave:

i) Front View

ii) Left Hand Side View

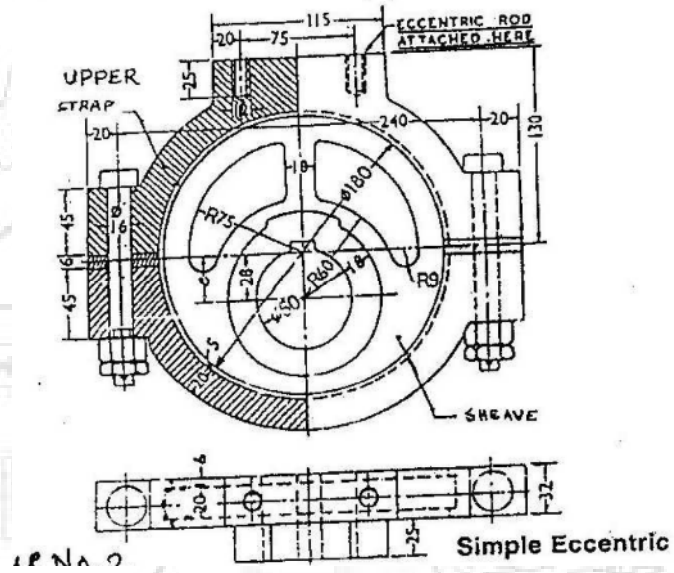

Ans.

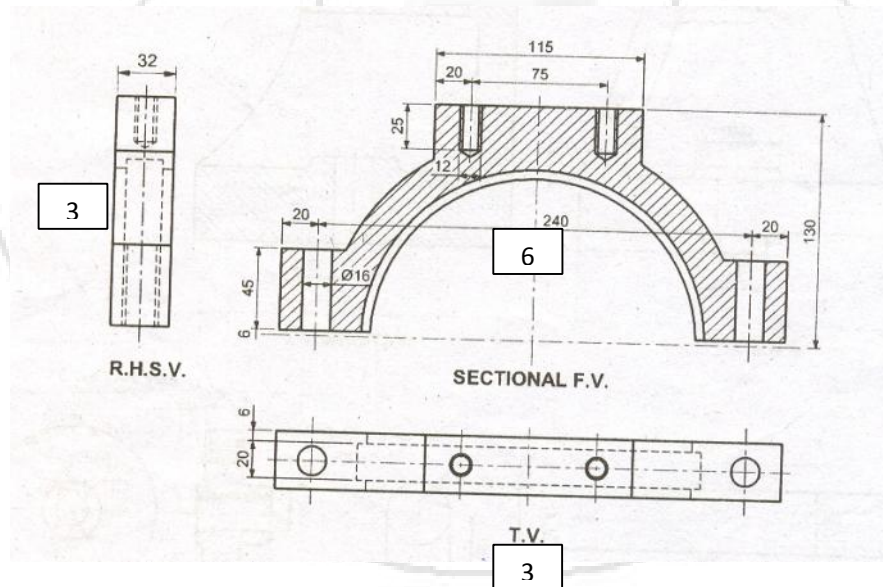

MACHINE DRAWING

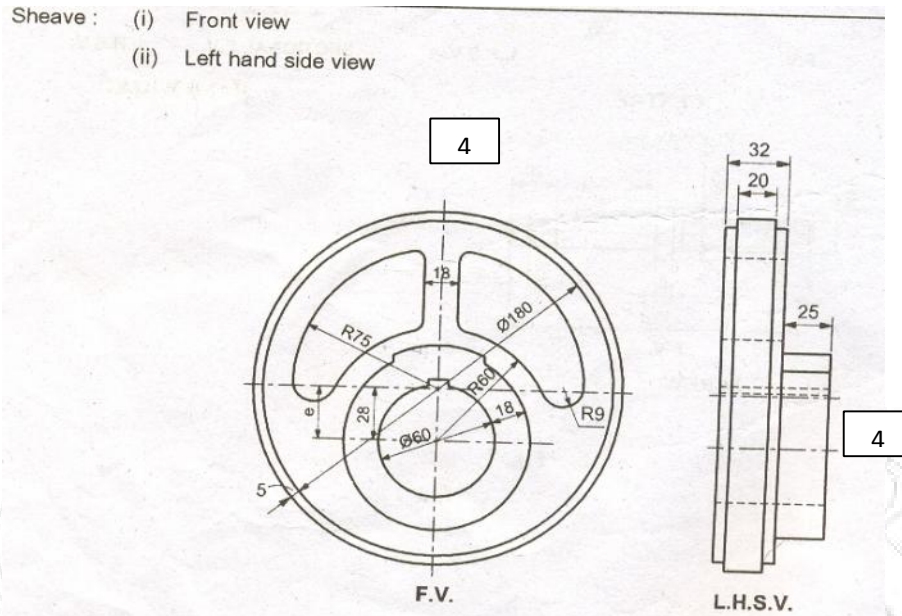

Q3. Figure shows an assembly of Milling Machine Tail Stock. Draw the following

- 1) Body:
 - i) Sectional F.V.
 - ii) Right hand side view
 - iii) Hand Wheel:
 - iv) Upper half sectional R.V.
 - v) Left hand side view
- 2) Center:
 - i) Front view
 - ii) Left hand side view
- 3) Screw (part no. 4):
 - i) Front view
 - ii) Right hand side view

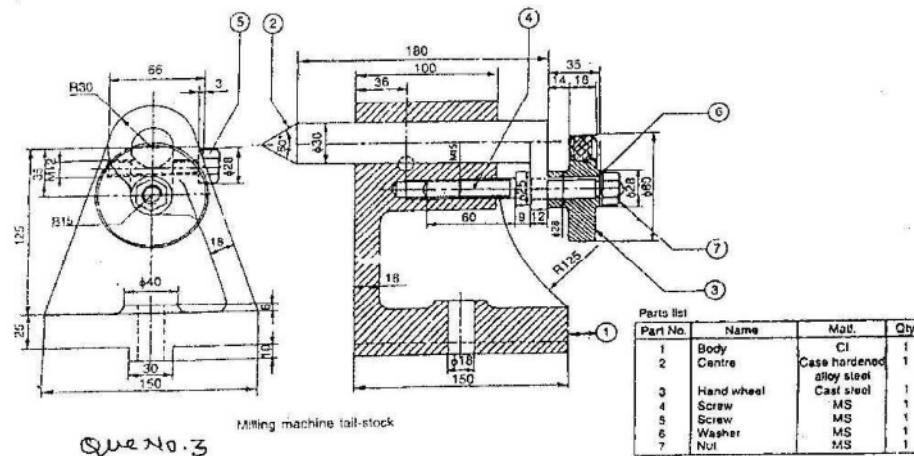

MACHINE DRAWING

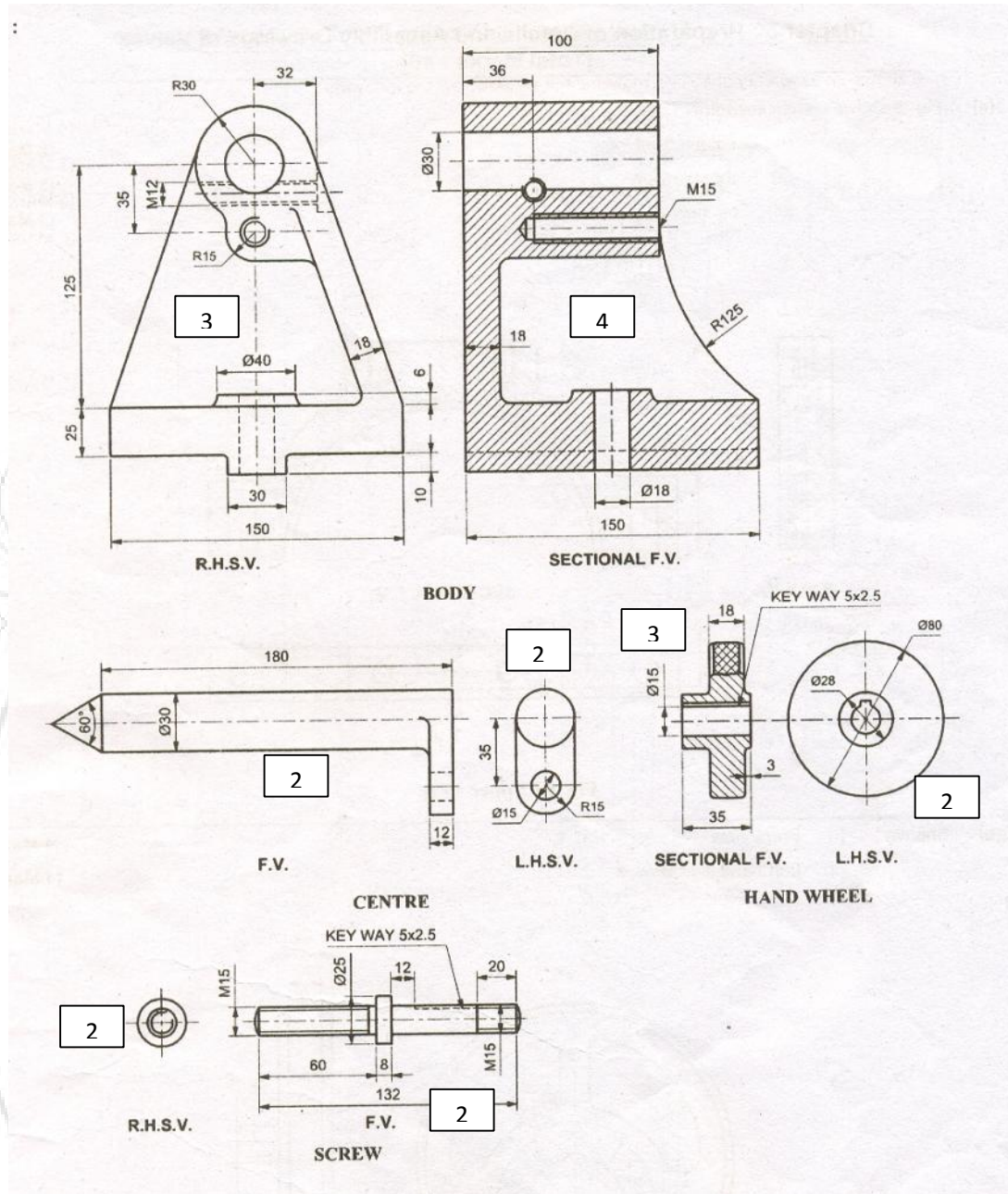

MACHINE DRAWING

Q4 a) A Vertical cone of diameter 100mm. and axis 100mm. is penetrated by a vertical square prism, having edges of base 45mm. The axis of the square prism is 10mm. away from the axis of the cone and plane containing both the axis is perpendicular to VP. A rectangular face of the square prism makes 30°. with VP. Draw front view and top view showing curves of intersection.

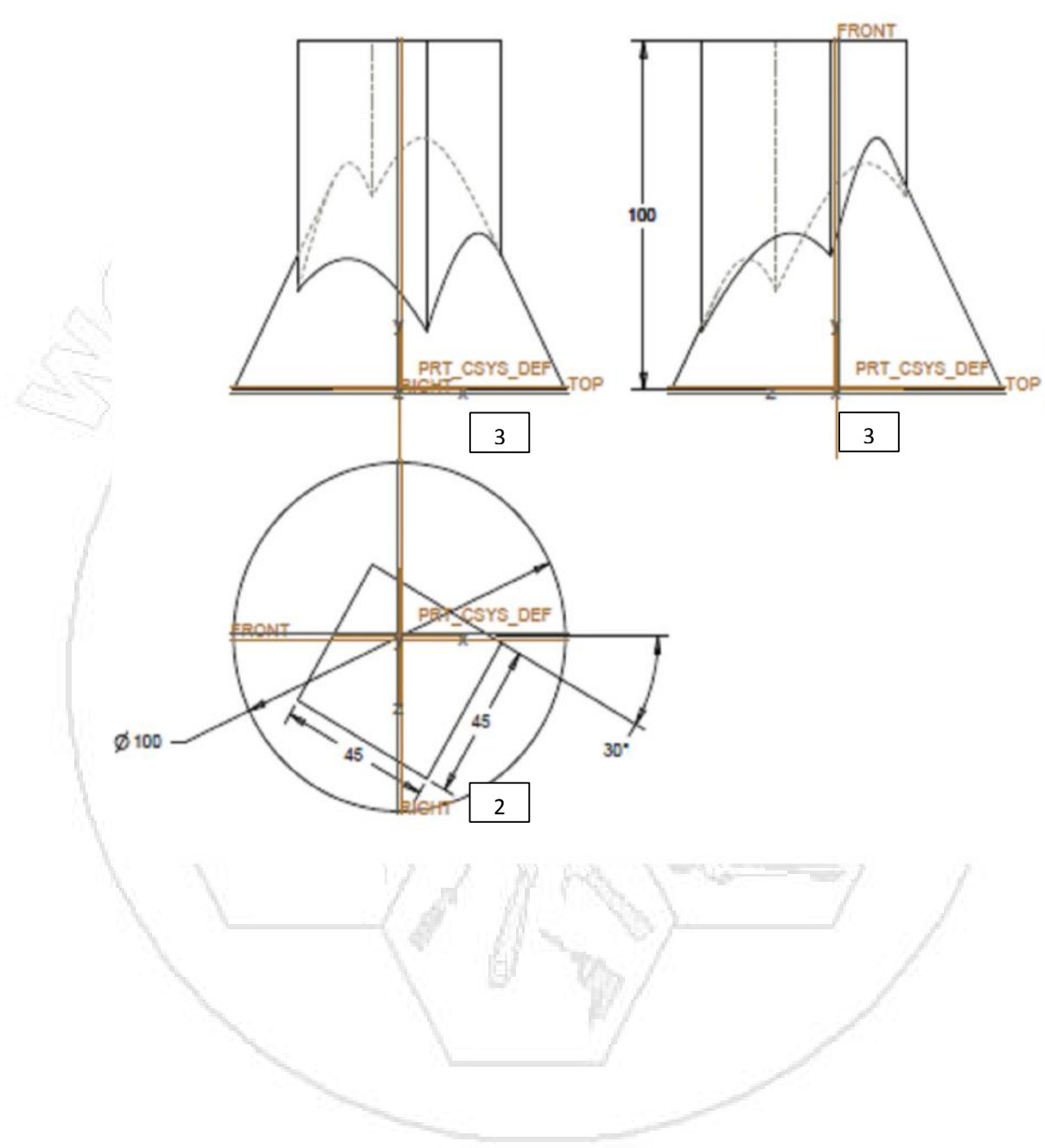

MACHINE DRAWING

Q4 b) A Square prism, side of base 50mm and height 70mm is resting on HP on its base with one of edges/sides of base inclined 30° to VP. The above prism is penetrated by horizontal triangular prism, side of base 50mm and length 100mm. the axis of triangular prism is parallel to VP and 5mm in front of the axis of square prism. A rectangular face of triangular prism is parallel to VP and nearer to the observer. Draw the projection and show the line of intersection.

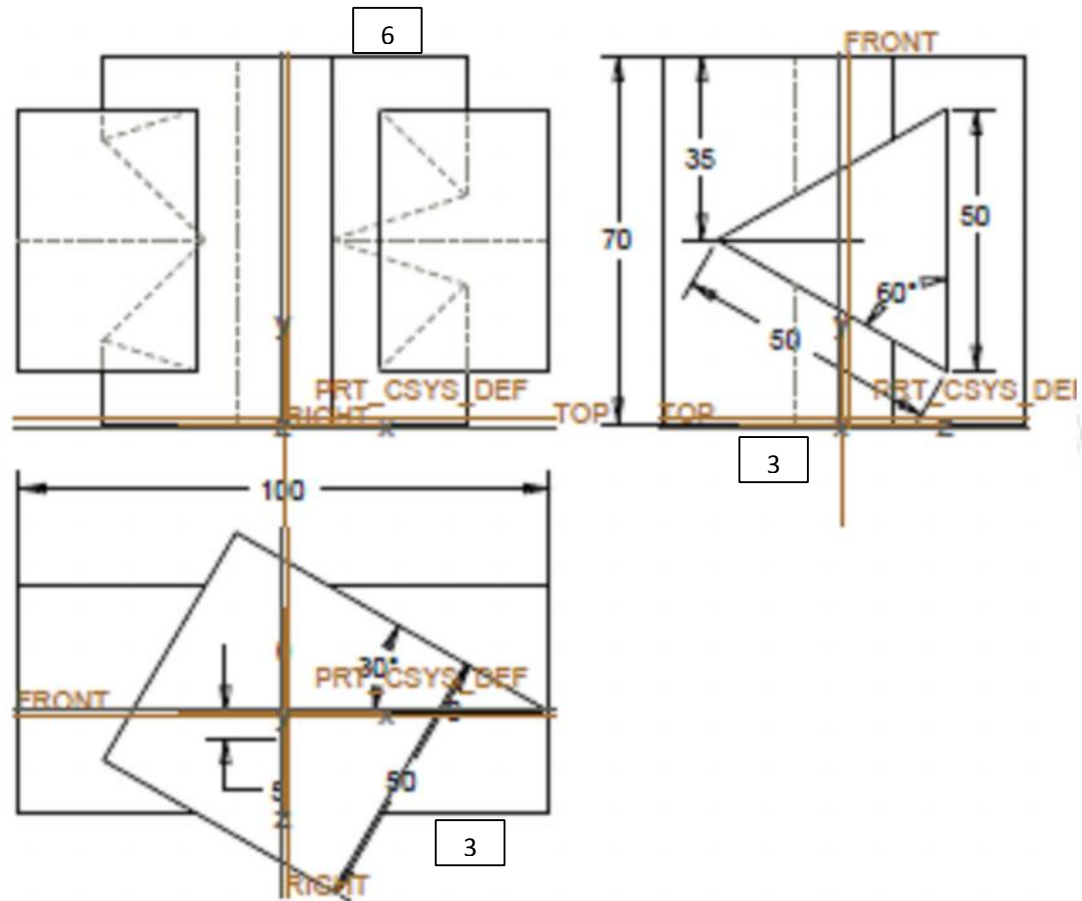

MACHINE DRAWING

Ans.

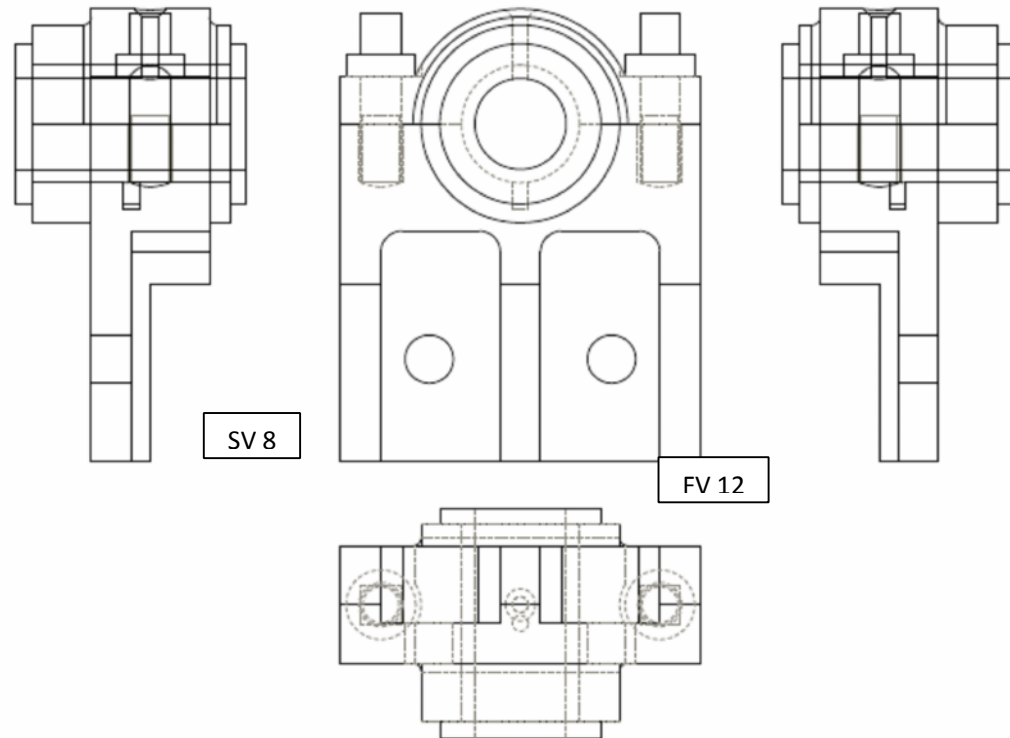
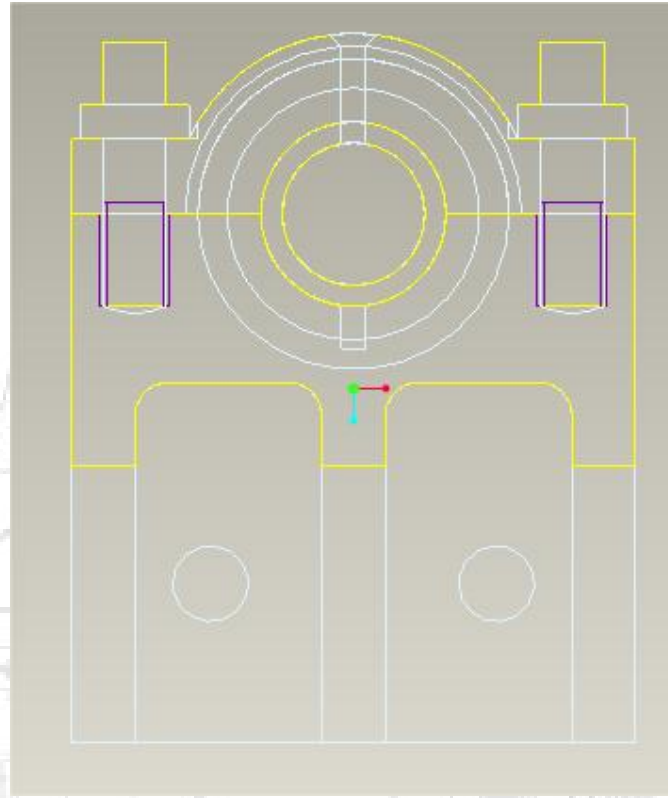

MACHINE DRAWING

Q.7) Draw neat and proportionate free hand sketches in two views of any three of the following :-

I. Fast and Loose Pulley:

i) Sectional Front View

ii) Side View

II. Knuckle Joint:

i) Sectional Front View

ii) Top View

III. Universal Coupling:

i) Sectional Front View

ii) Left Hand Side View

IV. Union Joint:

i) Sectional Front View

ii) Side View

Ans.

1)

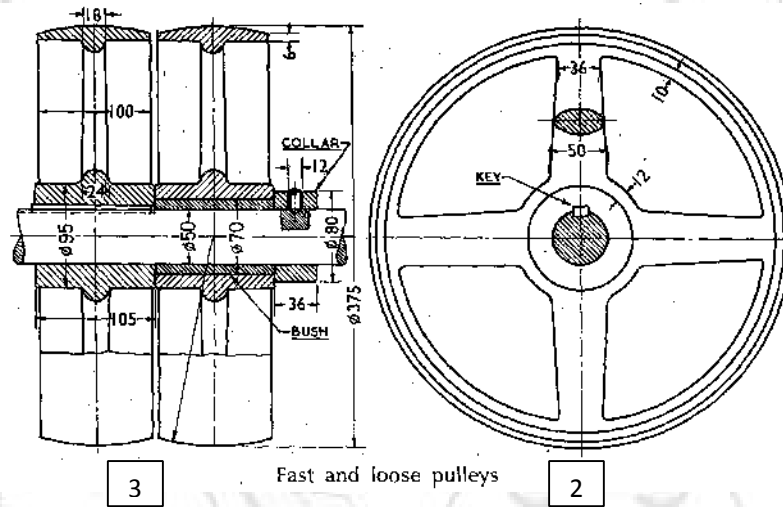

2)

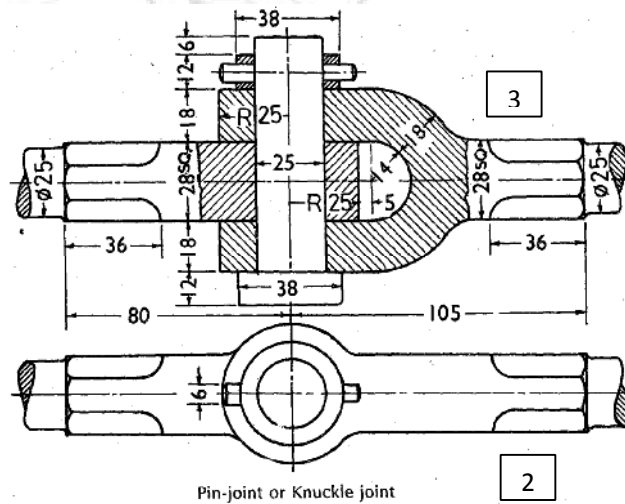

MACHINE DRAWING

3)

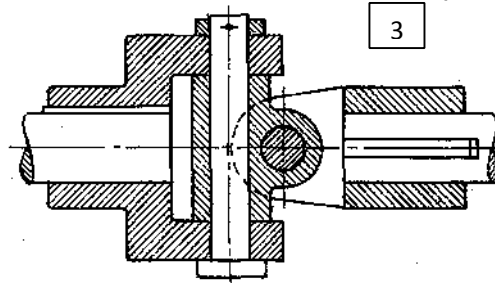

Universal coupling

4)

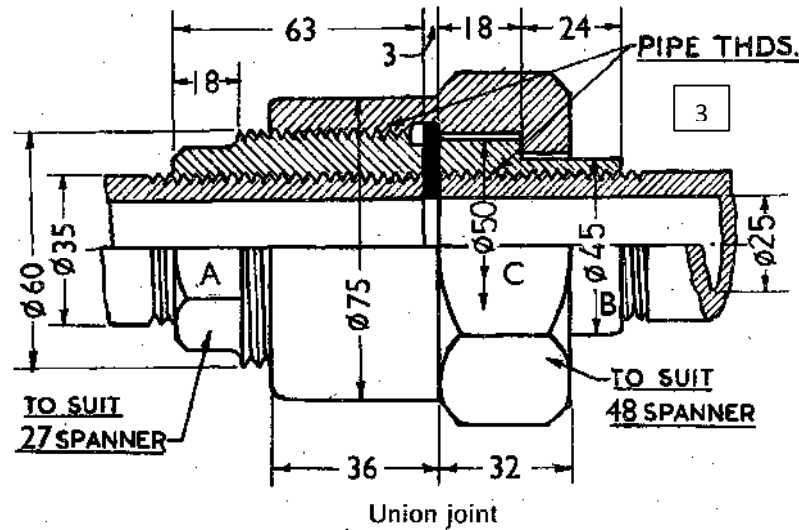

Union joint

Q7 b.

Explain meaning of $\varnothing 50 H_7/s_6$ value of tolerance are :

+25 μ m

+59 μ m

H₇

s₆

00 μ m

+43 μ m

Indicate type of fit. Draw with neat sketch.

Ans.

Dimensions of hole:

$$\text{Dimension of largest hole} = 50 + 25 \times 10^{-3} = 50.025 \text{ mm}$$

$$\text{Dimension of smallest hole} = 50 + 0.0000 = 50.000 \text{ mm}$$

Dimensions of Shaft:

$$\text{Dimension of Largest Shaft} = 50 + 59 \times 10^{-3} = 50.059 \text{ mm}$$

$$\text{Dimension of Smallest shaft} = 50 + 43 \times 10^{-3} = 50.043 \text{ mm}$$

As largest hole in above combination is smaller than smallest shaft, type of fit is **Interference Fit.**

